

Datasheet

HPT 5000/7000 USBL Transceiver



The HPT 5000 and 7000 Ultra-Short BaseLine (USBL) and telemetry transceiver is a high-performance platform which supports Sonardyne's Wideband®2 6G® instruments and offers significant improvements in acoustic positioning and telemetry performance.

The advanced multi-element processing enables transponders to be positioned more precisely, more quickly and more robustly due to improvements in signal processing algorithms and array design. When used as part of a complete USBL system such as Marksman or Ranger 2 and tightly integrated with Sonardyne's Lodestar attitude, heading and inertial navigation sensor, class leading performance in all water depths is achieved.

New functionality, such as 'Discovery Mode' which enables users to automatically detect previously deployed transponders including their configured address and channel, makes the system easier to use. The HPT also fully supports 6G LBL operations via Fusion LBL software.

The HPT transceiver is also a highly capable acoustic telemetry transceiver. Its multiple simultaneous channels enable robust high speed telemetry reception from Sonardyne's 6G subsea transponder modems and data loggers so reducing valuable vessel time.

Manufactured in aluminium bronze, the HPT is intended to be fitted temporarily or permanently to a vessel's through-hull or over-the-side pole.

A number of different array designs are available from full hemispherical coverage to specialist directional designs for ultra deepwater high noise environments.

Key features

- High performance USBL transceiver utilising Wideband 2 ranging and telemetry offer improved USBL precision and robustness
- Enhanced USBL array designs for improved noisy vessel and deepwater performance
- True simultaneous tracking of multiple transponders providing high update rates
- Seamless simultaneous positioning and telemetry of data whilst tracking
- Sonardyne Wideband 1, 2 and HRP400 ranging mode compatible
- Built in health checks including array and electronics diagnostics
- Discovery mode allows users to automatically scan for transponders deployed within acoustic range
- In water ambient noise monitoring
- Integral robust high data rate telemetry for fast acquisition of data from subsea instruments.
- Compatible with Marksman LUSBL, Ranger 2 USBL and Fusion 6G LBL systems
- Optional Ethernet connectivity

Specifications

HPT 5000/7000 USBL Transceiver

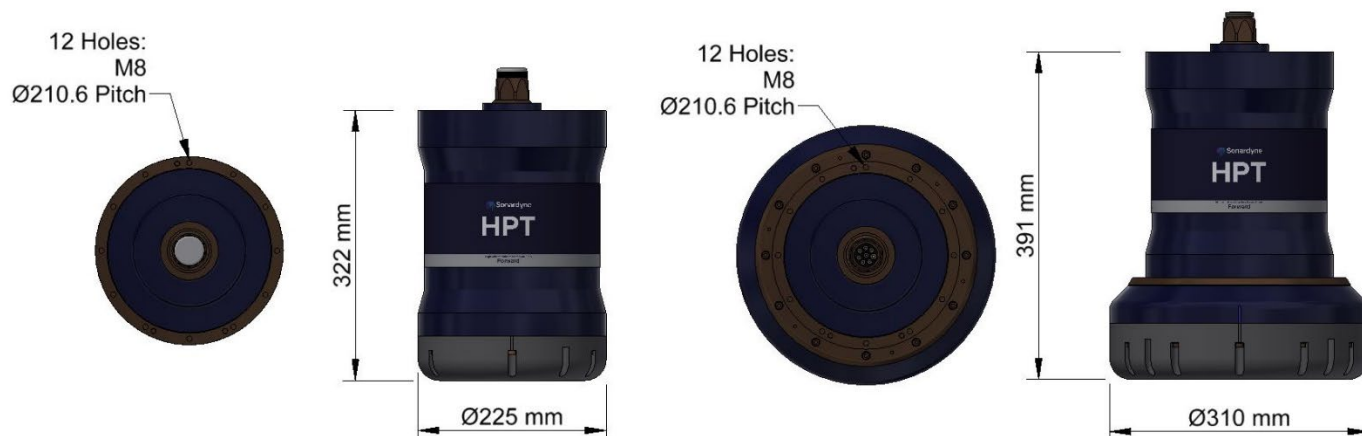

Feature	Type 8142-001	Type 8142-002 (deepwater optimised unit)
Operational frequency	MF (20–34 kHz)	MF (20–34 kHz)
Transceiver performance	Operating range	Up to 7,000 m
	Acoustic coverage	Up to ± 90°
	Range precision	Better than 15 mm
	Positioning repeatability	All transceivers tested to better than 0.1% of slant range 1 Drms
Transmit source level (dB re 1 µPa @ 1 m)	200 dB	200 dB
Tone equivalent energy (TEE) ¹	206 dB (13 JA)	206 dB (13 JA)
Electrical	48 V dc (±10%), Typical 15 W, Max 120 W	48 V dc (±10%), Typical 15 W, Max 120 W
Communication	RS485, baud rate switchable, Ethernet 100 Mbps	RS485, baud rate switchable, Ethernet 100 Mbps
Operating temperature	-5 to 40°C	-5 to 40°C
Storage temperature	-20 to 45°C	-20 to 45°C
Mechanical construction	Aluminium bronze	Aluminium bronze
Dimensions; length x diameter	322 x 225 mm	391 x 310 mm
Weight in air/water	26.7/15.3 kg	46.9/29.0 kg
Options	Tilted array adaptor	Tilted array adaptor

Note: The absolute accuracy of the system is dependent upon the quality of external attitude and heading sensors, beacon source level, vessel noise, water depth, mechanical rigidity of the transceiver deployment machine, SV knowledge and proper calibration of the total system using CASIUS.

¹ WBv2+ signals are 4x the duration of Sonardyne tone signals (WBv1 & WBv2 are 2x). The TEE figure shows the operational performance when comparing wideband and tone systems. Detection performance is directly related to the signal energy (Joules (Watt seconds)) and not power. WBv2+ signals are longer in duration (greater energy) than WBv1 and Tone, therefore the detection performance is the same or improved for low transmit source levels.